

## ISTRUZIONI D'INSTALLAZIONE ED USO

ATTENZIONE: LEGGERE E CONSERVARE LE PRESENTI ISTRUZIONI

Solo il rispetto scrupoloso delle indicazioni qui contenute in sede di montaggio e di uso garantiscono la sicurezza.

L'installazione e tutte le operazioni di manutenzione non ordinarie dovranno essere effettuate solo da personale qualificato.

**Disinserire l'apparecchio dalla rete di alimentazione ogni qual volta si agisce sullo stesso.**

Panzeri Carlo srl non si ritiene responsabile di eventuali danni a persone e/o cose derivati dalla errata installazione, cattivo uso o da modifiche non da essa apportate ai prodotti.

**Attenzione:** in fase di realizzazione del controsoffitto prestare attenzione alla disposizione della struttura di sostegno del cartongesso in modo da agevolare la realizzazione dei fori per gli apparecchi di illuminazione.

### MANUTENZIONE

Si raccomanda di pulire l'apparecchio usando solo uno straccio morbido. In caso di sporco persistente inumidirlo ed eventualmente usare sapone neutro.

NON USARE alcool e/o solventi.

Negli apparecchi con sorgente a LED le sorgenti stesse non sono in alcun modo sostituibili. In caso di danneggiamento deve essere sostituita tutta l'elettrificazione.



L'apparecchio non può essere smaltito nei normali rifiuti domestici ai sensi della direttiva europea 2002/96/CE in materia di apparecchi elettrici (waste electrical and electronic equipment - WEEE). Questa direttiva definisce le norme per la raccolta e il riciclaggio degli apparecchi dismessi valide su tutto il territorio dell'Unione Europea. Per la restituzione di un dispositivo dismesso, si prega di servirsi dei sistemi di restituzione e raccolta messi a disposizione nei singoli paesi di utilizzo.



Prodotto conforme alle norme di sicurezza e alle direttive europee vigenti.



Marchio unico di certificazione EAC (EurAsian Certification).



Non ricoprire l'apparecchio con materiale isolante o similare.

## OPERATION AND USE INSTRUCTIONS

ATTENTION: PLEASE READ AND SAVE THESE INSTRUCTIONS

The safety of this fitting is only guaranteed if the instructions are followed carefully.

Installation and all non-routine maintenance must be carried out only by qualified personal.

**Disconnect main voltage before taking any action on the fitting.**

Panzeri Carlo Srl is not responsible for any damage to persons and/or property resulting from improper installation, misuse, or unauthorized modifications made to their products.

**Caution:** when installing countertop pay attention to the arrangement of the support structure of the plasterboard in order to facilitate the realization of holes for the lighting fixtures.

### CLEANING

In order to clean the fitting use only a soft cloth. In case of persistent spots use only damp cloth and neutral soap.

DON'T USE alcohol and/or solvent

Fixtures with led: the LED cannot be partially replaced. If damaged all the power LED supply must be replaced.



The device may not be disposed of with household rubbish. This appliances is labelled in accordance with European Directive 2002/96/EG concerning used electrical and electronic appliances (waste electrical and electronic equipment - WEEE). The guideline determines the framework for the return and recycling of used appliances as applicable throughout the EU. To return your used device, please use the return and collection systems available to you.



Product complying with safety rules and EU directives.



Unique brand of EAC certification (EurAsian Certification).



Do not cover the unit with insulating material or similar.

## MONTAGE- UND GEBRAUCHSANLEITUNG

ACHTUNG: BITTE LESEN UND BEWAHREN SIE DIESE ANLEITUNGEN

Um die Sicherheit der Leuchte zu gewährleisten, beachten Sie bitte unbedingt diese Anleitung.

Die Installation und alle Nicht-Routine-Wartungsarbeiten dürfen nur durch Fachpersonal durchgeführt werden.

**Vor jeglichen Arbeiten ist die Stromversorgung abzustellen.**

Panzeri Carlo srl ist für eventuelle Personen- und/oder Sachschäden, die sich aus einer falschen Installation, einem unsachgemäßen Gebrauch und durch unbefugte Änderungen am Produkt ergeben, nicht verantwortlich.

**Achtung:** Bei der Konstruktion der Zwischendecke ist die Stützstruktur des Gipskartons so anzuordnen, dass die Bohrungen für die Beleuchtungskörper einfach durchgeführt werden können.

### REINIGUNG

Reinigung nur mit einem weichen Tuch vornehmen. Bei stärkerer Verschmutzung ein feuchtes Tuch und neutrale Seife verwenden. Auf keinen Fall Alkohol oder andere Lösungsmittel benutzen.

Bei den Geräten mit LED sind die Quellen auf keine Weise ersetzbar. Bei Schadensnahme muss die gesamte Elektrifizierung ersetzt werden.



Das Gerät darf nicht mit dem Hausmüll entfernt werden. Dieses Gerät ist entsprechend der europäischen Richtlinie 2002/96/CE über Elektro- und Elektronik-Altgeräte (waste electrical and electronic equipment - WEEE) gekennzeichnet. Die Richtlinie gibt den Rahmen für eine EU-weit gültige Rücknahme und Verwertung der Altgeräte vor. Für die Rückgabe ihres Altgeräts nutzen Sie bitte die Ihnen zur Verfügung stehenden Rückgabe- und Sammelsysteme.



Das Produkt entspricht den gültigen Sicherheitsvorschriften und EU-Richtlinien



Eineg Markenzeugnis EAC (EurAsian Certification).



Das Gerät nicht mit Isoliermaterial oder Ähnlichem bedecken.

## INSTRUCTIONS D'INSTALLATION ET UTILISATION

ATTENTION: S'IL VOUS PLAÎT LIRE ET CONSERVER CES INSTRUCTIONS

Seulement le respect scrupuleux des conseils ici contenus au moment de l'installation et de l'utilisation est une garantie de sécurité.

L'installation et les opérations de maintenance non-routine doivent être effectuées uniquement par du personnel qualifié.

**Débrancher l'appareil du réseau d'alimentation avant de procéder à toute opération.**

Panzeri Carlo srl n'est pas responsable de tout dommage aux personnes ou choses résultant d'une mauvaise installation, mauvaise utilisation, ou de modifications aux produits apportés par les autres.

**Attention:** au moment de réaliser le faux plafond faire attention à la disposition de la structure de soutien du carton-pierre de façon à faciliter la réalisation des trous pour les appareils d'éclairage.

### ENTRETIEN

On conseille de nettoyer l'appareil seulement avec un chiffon souple. Pour enlever les taches persistantes utiliser un chiffon humide avec du savon neutre.

Ne pas utiliser d'alcool ni de solvants.

Dans les appareils avec source à LED les sources mêmes ne sont pas remplaçables. En cas d'endommagement il faut substituer toute l'électrification.



L'appareil ne peut pas être jeté dans le flux normal des déchets municipaux selon la Directive Européenne 2002/96/CE sur les Déchets des Equipements Electriques et Electroniques (DEEE) (Waste Electrical and Electronic Equipment-WEEE). Cette directive définit les normes de collecte et le recyclage des appareils usagés sur tout le territoire de l'Union Européenne. Pour la restitution d'un appareil usagé, il faut se servir des systèmes de restitution et de collecte offerts dans chaque pays d'utilisation.



Produit conforme aux règles de sécurité et aux règlements de l'union européenne.



Marque unique de conformité EAC (EurAsian Certification).



Ne pas couvrir l'appareil avec du matériel isolant ou similaire.

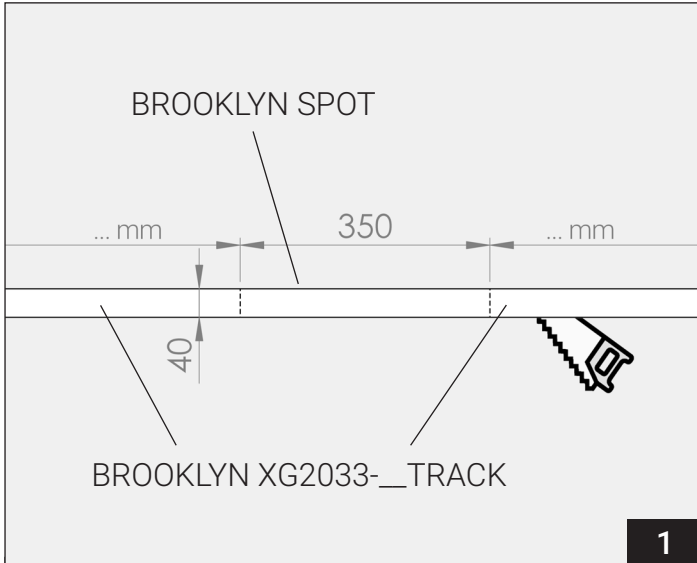

Predisporre i cavi per i collegamenti elettrici 220-240 V

*Prepare the cables for their connection 220-240 V*

Die Kabel für den Elektroanschluss sind zu verlegen 220-240 V

*Préparer les câbles pour le branchement électrique 220-240 V*

**2**

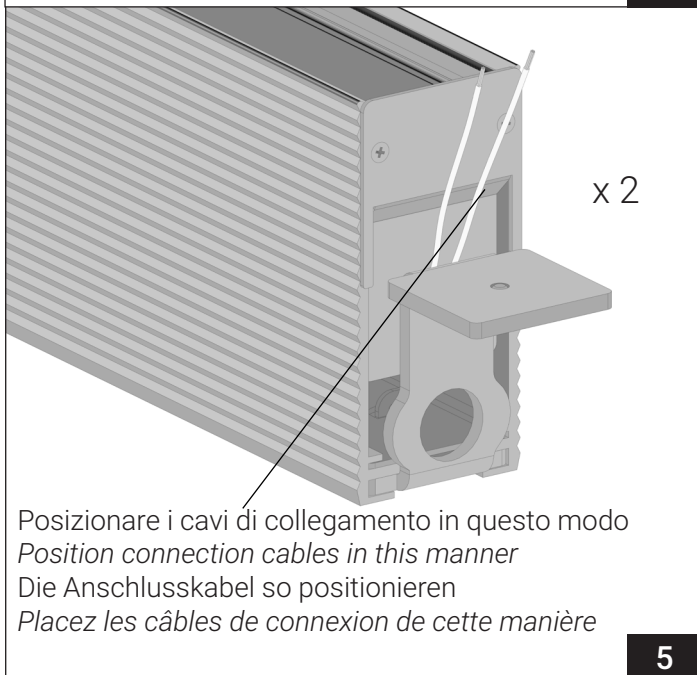
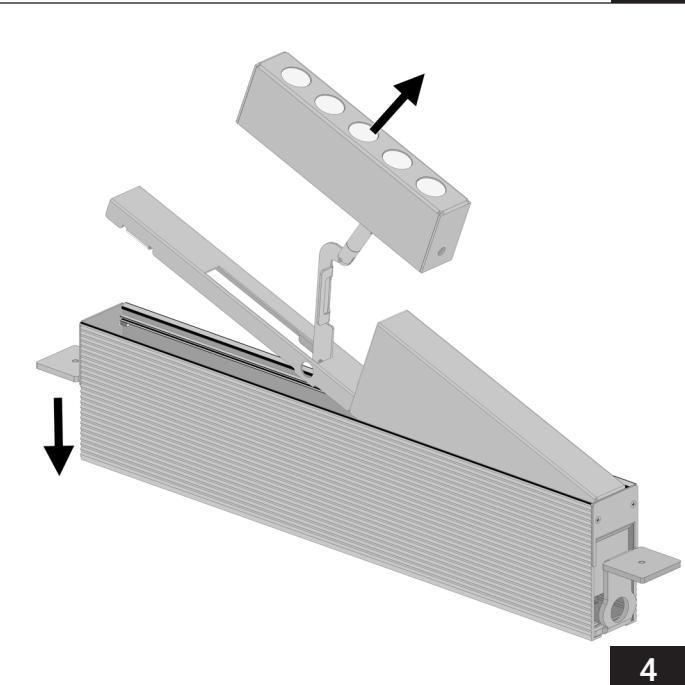
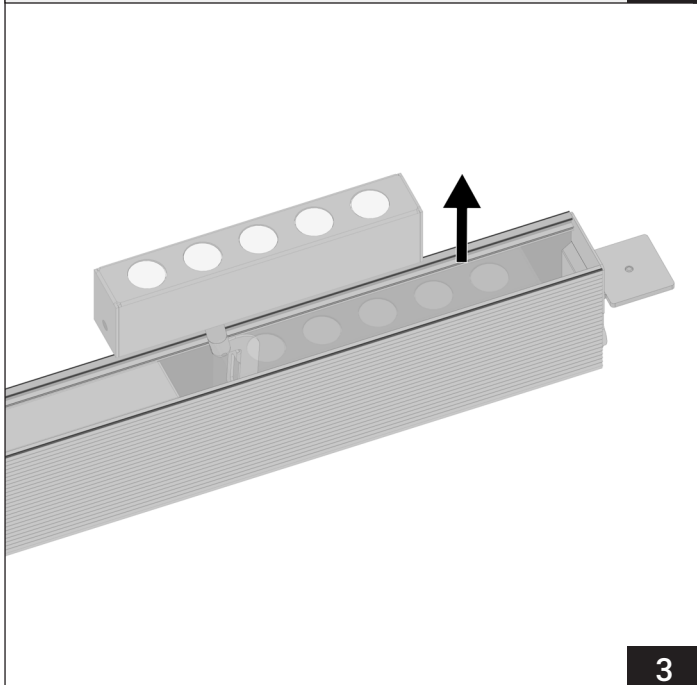

Cavi di collegamento 24 V per Brooklyn XG2033  
*Connection cables 24V for Brooklyn XG2033*  
24-V-Anschlusskabel für Brooklyn XG2033  
*Câbles de connexion 24 V pour Brooklyn XG2033*

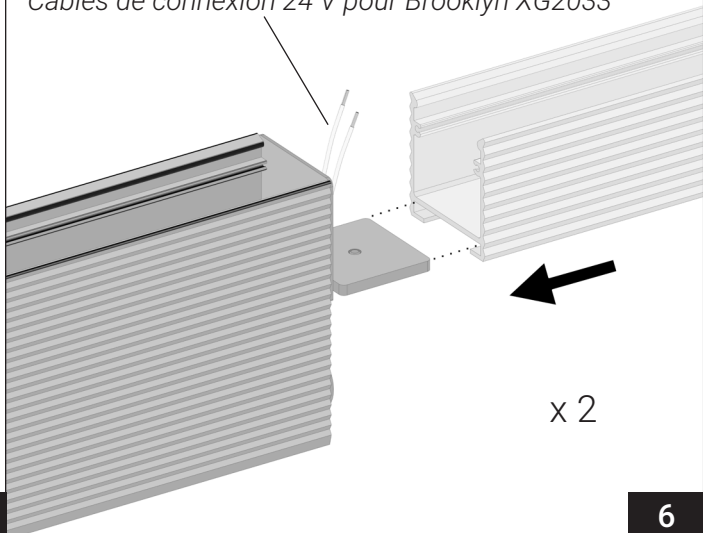

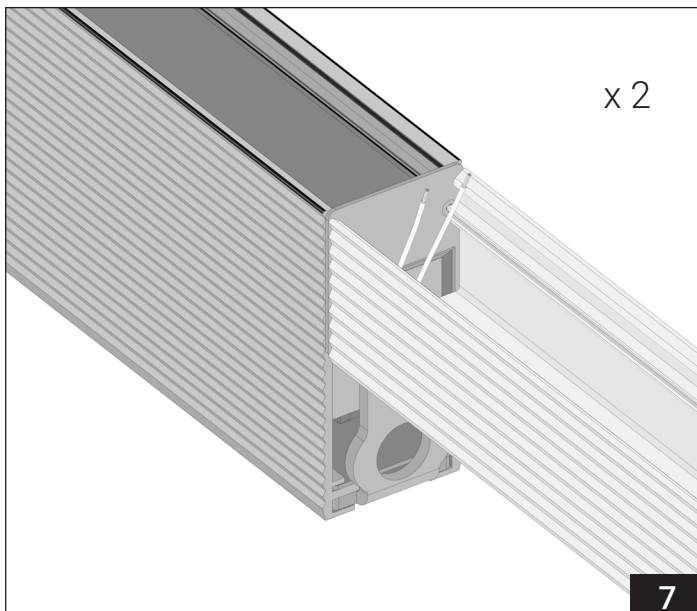

7

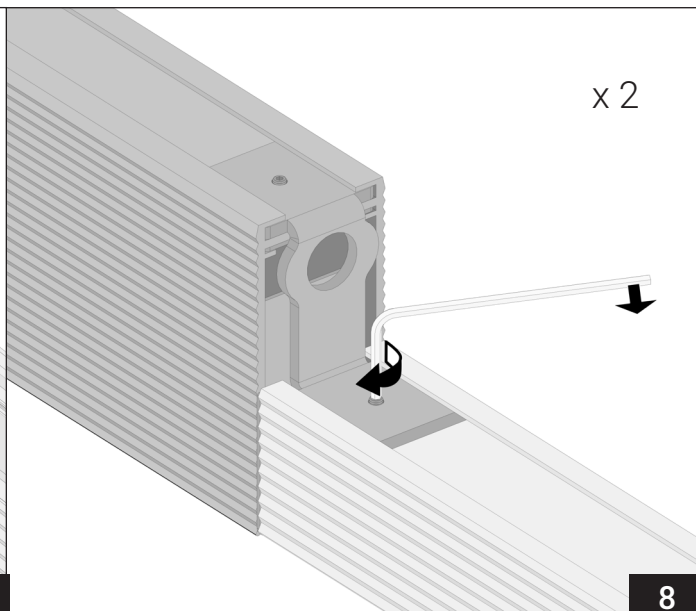

8

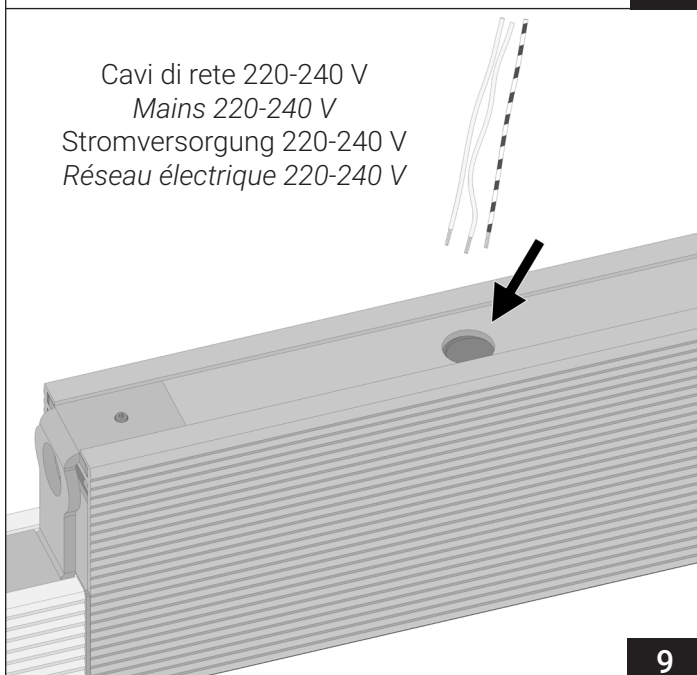

Cavi di rete 220-240 V  
Mains 220-240 V  
Stromversorgung 220-240 V  
Réseau électrique 220-240 V

9

Seguire le istruzioni d'installazione di Brooklyn XG2033  
Follow the installation instructions of Brooklyn XG2033  
Die Installationsanleitung für Brooklyn XG2033 beachten  
Suivez les instructions d'installation de Brooklyn XG2033

10

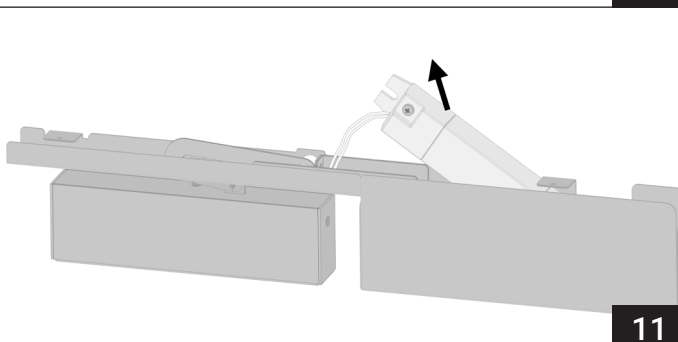

11

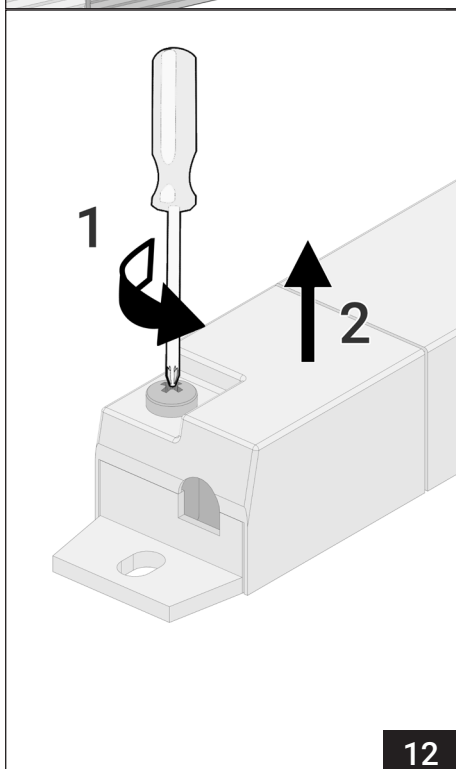

12

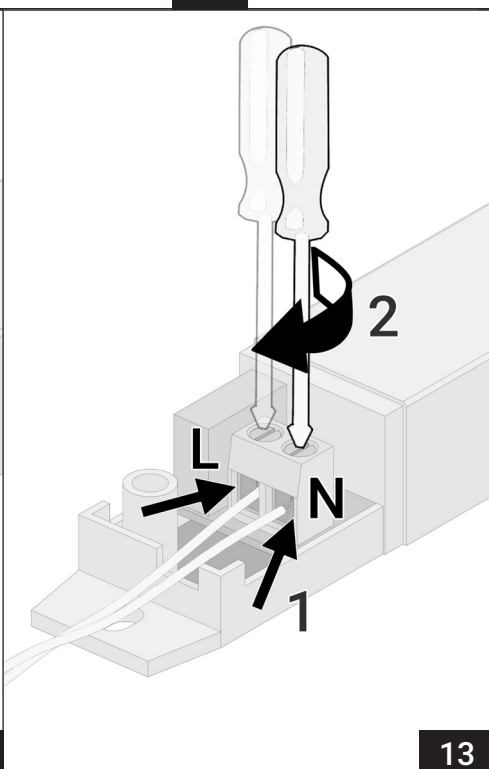

13

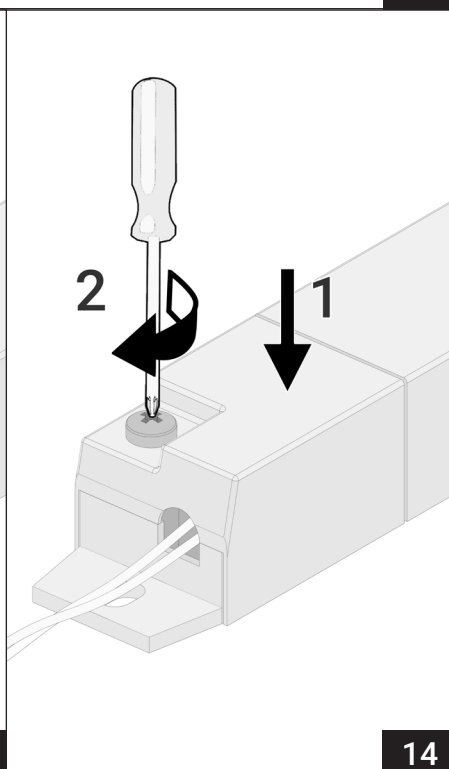

14

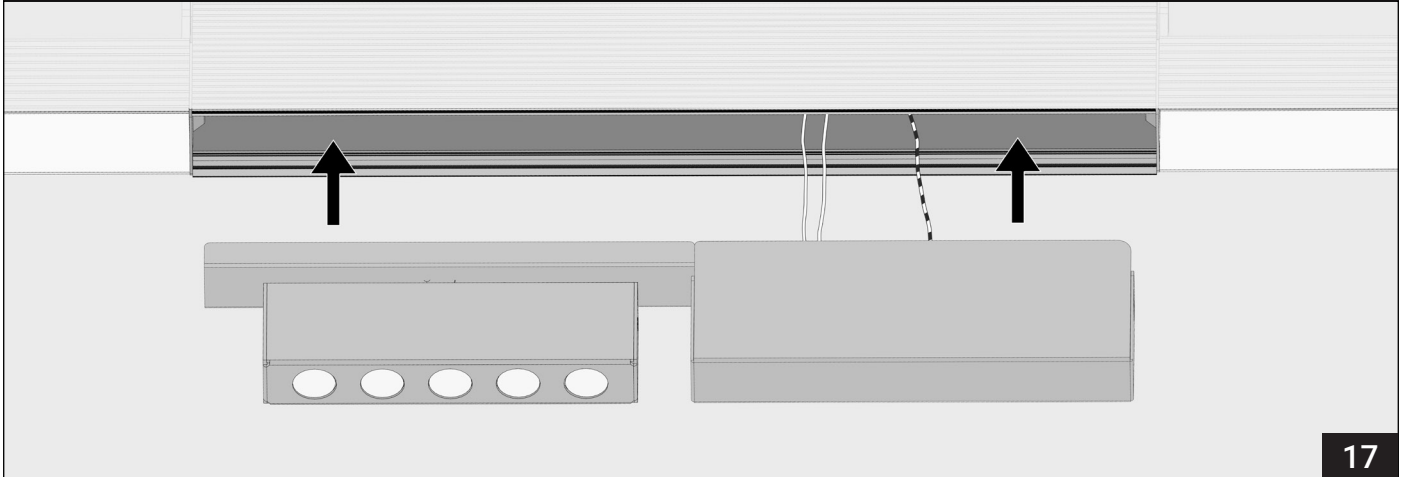
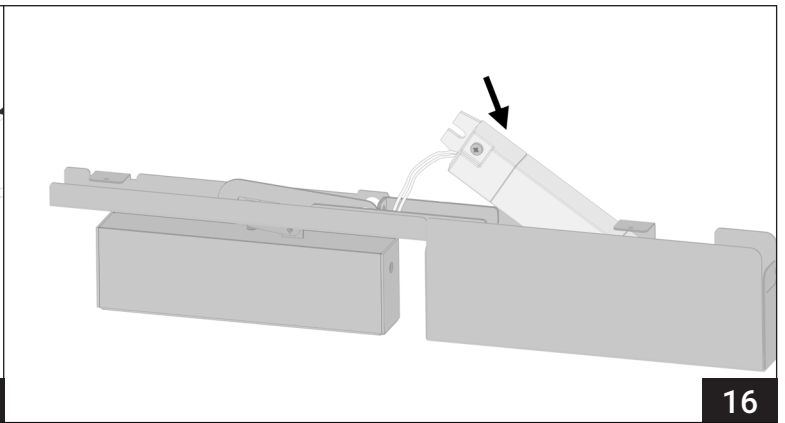
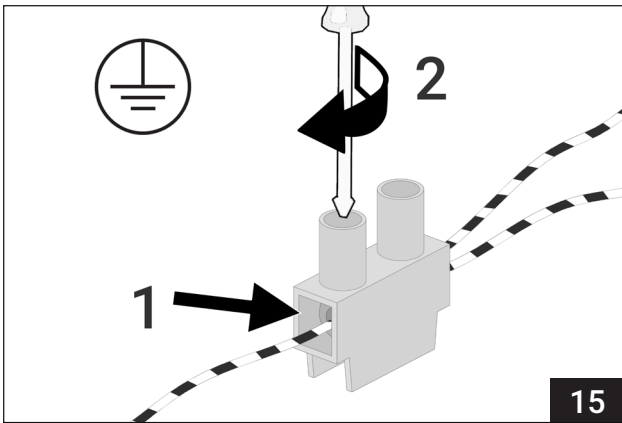

Movimenti    *Movements*    Bewegungen    *Mouvements*

